

Evaluation of the Use of BIM Tools for Construction Site Utilization Planning

Abhijeet Deshpande, Ph.D. and J. Blake Whitman

Auburn University
Auburn, Alabama

Construction Site Utilization Planning (CSUP), also known as jobsite layout planning, has the potential to improve the efficiency of the construction process, enhance the schedule and budgetary performance of a project, and improve the safety of construction operation. Traditionally, this planning has been done using two dimensional paper based design or AutoCAD® / PDF files. The data rich three dimensional context provided by Building Information Models can be leveraged to improve the CSUP process and communicate the construction execution plan effectively to all stakeholders. This paper discusses the advantages and challenges in using currently widely accepted tools for Site Utilization Planning. BIM models are inherently composed of parametric objects. The majority of BIM tools are predominantly built for the design community. This has resulted in a lack of available family objects that can be used to model construction site operations. This paper provides a detailed discussion of the developments that need to occur so that BIM models can be effectively used for CSUP. The benefits of integrating a site utilization plan with a construction schedule to produce powerful temporal 4D simulations are also discussed.

Key Words: Construction Site Utilization Planning, Virtual Construction, BIM, Site Utilization Planning Families

Introduction

Construction Site Utilization Planning (CSUP) is a decision making process for determining the locations of temporary facilities within the boundary of a construction site by identifying spatial relationships and developing the best alternative solution so that unproductive interaction between facilities are kept to a minimum. Temporary Facilities (TFs) are those facilities and areas delineated to specific tasks that support the construction process. Temporary facilities are typically not a part of the permanent structure and have relatively short life spans. Examples of temporary facilities associated with construction projects include laydown areas, unloading areas, material paths, staging areas, personnel paths, storage areas, prefabrication areas, work areas, tool and equipment areas, debris paths, hazard areas, and protected areas (Riley and Sanvido 1995). The number, type, and size of temporary facilities depend upon the project type, scale, design philosophy, and construction execution strategy. Site Utilization Plans, also known as Jobsite Layout Plans, are documents that depict the locations of temporary facilities within the construction site boundary. Jobsite layout plans are similar to the construction plan and schedule in that they are long-term and consider all factors of the construction process. Optimum site utilization plans are designed to minimize the labor involved with movement of materials so that workers can spend the majority of their time performing construction tasks.

Typically, a project manager is responsible for developing a site utilization plan based on past experience, knowledge, intuition, and imagination (Osman et al. 2003). In the absence of a well-developed site utilization plan, many problems can occur resulting in delays and cost overruns. Site utilization planning is impacted by various project management tasks such as scheduling, selection of construction methods, procurement, material management, manpower, and equipment planning (Elbeltagi 2008). Despite the importance of site utilization planning, it is often done in a speedy manner or sometimes overlooked completely (Mawdesley et al. 2002). The results of such acts reflect in the day-to-day operations of a project, making it difficult to manage site operations. The decision to develop good site utilization plans early on in a project can have a significant impact on site operations. Traditionally, contractors use two dimensional AutoCAD drawings, PDF overlays or even drawing by hand when developing site utilization plans. Building Information Modeling is revolutionizing the construction

industry and redefining work flows. Contractors have aggressively started using Building Information Models in the construction phase for schedule simulations, clash detections, and performing quantity takeoffs. This paper provides a concise review of potential benefits of the use of Building Information Models in site utilization planning and the capabilities and weaknesses of commonly used modeling tools.

The objective of this paper is to identify benefits and current challenges associated with developing site utilization plans within the three dimensional, data rich BIM design environment. This paper presents an evaluation of Autodesk[®] Revit[®] as a tool for the development of site utilization planning families in the BIM design environment because of its wide acceptance throughout the construction industry. The capabilities and limitations of the current version (2014) are evaluated and ideas for improvement are proposed.

Background

Building Information Modeling (BIM)

Building Information Modeling (BIM) has become a very effective tool in the architecture, engineering, and construction industry. BIM tools have provided a common interface in which multiple users can create, store, and retrieve information pertaining to a construction project. One of the most noted benefits of using BIM is that an accurate virtual model of the structure is digitally constructed in three-dimensions, thus allowing all the project participants an opportunity to see what is to be constructed (Azhar 2011). This significantly decreases any misunderstanding that might be associated with the more traditional two-dimensional drawings. Recent years (2009~2012) have seen a surge in the adoption of Building Information Models (BIMs) by construction contractors to effectively and efficiently manage complex construction projects which need to be delivered under increasingly compressed schedule and budgetary requirements. The 2012 SmartMarket report published by McGraw-Hill Construction noted that construction contractors are now outpacing architecture firms in the adoption of BIM tools (McGraw-Hill 2012). According to the report, the percentage of contractors intensively using BIM in their processes is projected to go up from twenty one percent in 2009 to fifty five percent in 2014. The expertise and knowledge of the BIM tools is also projected to increase significantly over this time period.

Construction contractors are increasingly using BIMs for constructability analyses, improving communication with other stakeholders, and creating time-lapsed (4D) simulations of the construction processes over the project life cycle. As defined by Dodds and Johnson (2012), a 4D model represents the various activities of a construction project constrained to a project schedule. Information obtained from a 4D simulation can also include clashes between objects. This information can potentially reduce rework and save a significant amount of time and money due to the simple fact that errors can be rectified prior to the start of field installation. In most cases, however, these simulations involve the objects within the building systems that have been defined by the various design professionals.

Most of the Building Information Modeling tools have traditionally been developed with the needs of the designers in mind and construction contractors are considered downstream users, i.e. consumers of the design information (BIMs) produced by the A/E professionals. While software products such as Navisworks[®], VICO Office[®], and SYNCHRO[®] have been developed with the needs of the construction contractors in mind, these tools often only integrate models created by designers and add schedule and cost information to them for various analyses. These tools lack native capability of modeling construction objects; as well as, equipment and temporary facilities that are vital for effective planning of construction operations.

As construction projects become more elaborate and complex, the construction community is facing challenges associated with managing projects within tight budgetary constraints, compressed schedules and stringent safety requirements. As discussed earlier, the predominant use of BIM in aiding the management of construction projects has been limited to simulating the sequence of assembling components defined by the architectural, structural, HVAC and MEP designers; as well as, detecting clashes and calculating clearances between components. The process of construction, specifically the means and methods of construction, are generally not visualized or simulated. Thus, the simulation of the construction process, at best, is partial.

Review of Published Research Literature

Site utilization planning is an inherently complex problem that is intractable to humans as well as powerful computers. The layout problems are known to be NP-hard (Nondeterministic Polynomial time hard) wherein no known polynomial time algorithms exists and the identification of a perfectly optimal solution may require exponential computation time (Arikaran et al. 2010). Over the last two decades, a substantial amount of research effort has focused on the development of meta-heuristic algorithms for the optimization of labor and material movement at construction sites (Liggett 2000). In some studies, researchers have added objectives, such as safety, to the optimization process, making it a multi-objective optimization process (Ning et al. 2010). Researchers generally agree that due to the intractability and complexity of the problem, no well-defined optimization methods can guarantee an optimal solution that takes all possible elements into account. Some recommend understanding the constraints of a site (e.g., topography, permanent facilities, etc.) and taking them into consideration when developing a site utilization plan as a good starting point (Chau and Anson 2002). Very little evidence exists of the use of complex optimization techniques being used for site layout planning in the construction industry.

The layout of temporary facilities is inherently graphical in nature due to the fact that site boundaries, existing permanent structures, the structure to be constructed, and temporary facility locations all occupy space in three dimensions. Layout planning can be done effectively graphically because of inherent human ability to conceptualize space and inter-relationships between spaces in two or three dimensions. The following notable studies have proposed solutions that utilize this idea. ArcSite (Cheng and O'Connor 1996) utilized the capabilities of Geographic Information System (GIS) integrated with database management systems (DBMS) to assist designers in solving the layout planning problem using the knowledge based information provided by the user. In this model, GIS functionalities (for example, buffer, erase, overlay) can be performed in the coverage files that identify a feasible layout to solve the problem. Osman et al. (2003) developed a novel hybrid approach in which a genetic algorithm was integrated within the computer aided design AutoCAD® environment to optimize the location of temporary facilities on site. While most systems that use mathematical techniques aim at achieving one or more goals (typically minimization of cost) under problem-specific constraints, this hybrid system, in contrast, performs the optimization based on the geometric data provided in the AutoCAD® drawing (for example, site boundaries, permanent facilities, obstacles). The drawing is used to detect space and ensure constraint satisfaction (facilities placed within site boundaries and non-overlap). While the first task (space detection) is performed only once to identify space available for placing temporary facilities, the latter task (constraint satisfaction) is performed in every cycle of the optimization process. Retik and Shapira (1999) integrated site-related activities into the planning and scheduling of a modeled project. This virtual-reality-based model was developed so that site related activities could be simulated over the project duration (Retik and Shapira 1999). The use of such virtual-reality based models, or even extensive simulation of means and methods of construction remains limited due to the lack of availability of software products that work right out of the box and don't require extensive knowledge on software manipulation.

Virtual Site Utilization Planning

Many owners are now beginning to require that the architects and engineers develop BIM models for large projects because it is cost effective to detect design flaws early and redesign prior to installation. The main benefit of developing site utilization plans within BIM is that it would allow additional use of the BIM-based building design models already created by the designers. The BIM model presents an excellent 3D context for planning construction operations. Additionally, the team planning the execution of the construction can use these models to come to a common and shared understanding of the work involved. In addition, specialty sub-contractors can effectively get involved in the development of the execution plan for the project.

Object Based Design Paradigm

Building information models are inherently object based parametric models. They are not composed of objects that are defined only by fixed geometry. The objects are represented in the model by parameters and rules that determine

the geometry of the object; as well as, non-geometric properties and features. The parameters and rules can be expressions that relate to other objects, thus allowing objects to only exist in the context for which they were defined. The objects update dynamically with changes in design. In REVIT[®], the object oriented design paradigm is implemented using families of objects. A *family* is a group of elements that possess a shared set of properties (parameters), and a graphical representation. The various elements belonging to a family may have different values for some or all of their parameters, but the set of parameters (their names and meanings) is the same. These variations within the family are called *family types* or *types*. When a user adds an object of a family type in a model, a family type instance is created. Each element instance has a set of properties, in which the user can change some element parameters independent of the family type parameters. These changes apply only to that specific instance of the element (AUTODESK[®] REVIT[®] 2014).

REVIT[®] provides a very extensive set of system families natively to model architectural, structural and system (HVAC, MEP) objects. For example, REVIT[®] Structure provides well-developed parametric families to model steel and concrete beams, columns and various types of concrete foundations. Additionally, software extensions can be used to model structural concrete reinforcement and connections between structural steel members. Each of these objects has an extensive set of parameters that accurately define its geometric characteristics, its use and its contextual relationships with other objects.

Unfortunately, the support for creating objects for construction execution planning in most modeling software products, including REVIT[®], is very limited. This is due to the fact that these software products are purpose built to meet the needs of the building design community. The families that can be possibly used for site utilization planning include concrete truck, construction crane, construction trailer, porta-john, scaffolding, pick-up truck, waste container, etc. These families have been classified under the logistics category. These families are very generic and have very limited parametric control over their behavior. For example, Figure 1 shows a 3D view of hydraulic crawler crane family currently available to modelers and Figure 2 shows the parametric properties of the crane.

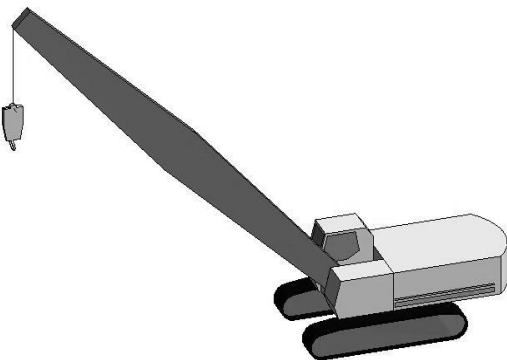

Figure 1: REVIT[®] Family: Construction Crane

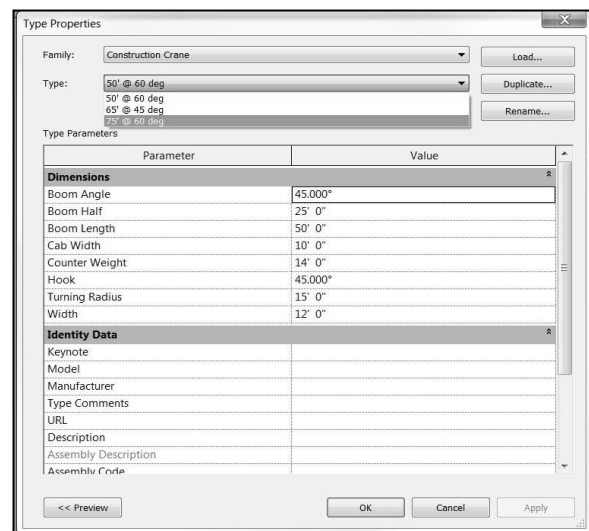

Figure 2: Construction Crane: Type Properties

From Figure 2, one can see that the software offers very limited Types (50' @ 60 deg, 65' @ 45 deg, 75' @ 60 deg) in the Construction Crane family. More importantly, a very limited number of parameters are specified in this family. The Boom Angle can be changed about the pivot point within the model; however, the swing angle cannot be changed. The Boom length adjustments are also very limited, i.e. full length and half length. The structure and dimensions (other than length) of the crane boom are not parameterized. Most importantly, there are no parameters to represent the lifting capacity of the crane at various boom lengths and angles of lift. In its current state, this model can only be used to visualize a generic crawler crane at a construction site. It is of little use for actual planning of critical lifts on a construction site.

Construction crane manufacturers publish detailed specifications of each crane including detailed crane dimensions, lift rating for various boom lengths, radii, angle, working radius ranges, boom composition, etc. For the sake of comparison, an abbreviated version of the lift rating chart and the working radius chart of the TEREX[®] American Hydraulic Crane model HC 40 is shown in Figure 3 and Table 1.

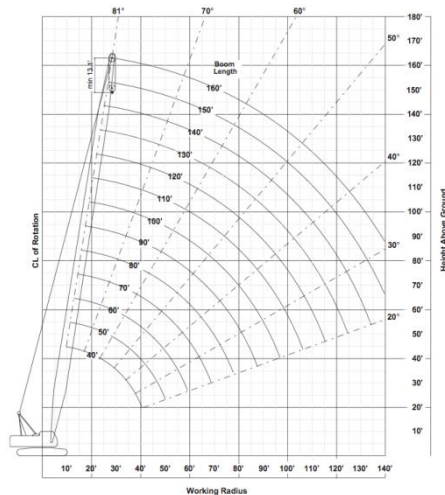

Figure 3: TEREX HC 40 Working Radius Chart

Table 1: TEREX HC 40 Lift Rating Chart

Boom Length	Radius (Feet)	Boom Angle (Degrees)	Side Frames Extended (Pounds)	From Boom Pt. to Ground (Feet)	
40' (12.2M)	10	80.3	100,000*	45	
	12	77.4	100,000*	44	
	15	73.0	93,390	44	
	20	65.3	59,020	42	
	25	57.1	42,780	39	
	30	48.1	33,370	35	
	35	37.5	27,190	30	
	40	23.4	22,840	21	
	50' (15.2M)	12	80.0	100,000*	55
		15	76.4	93,310	54
20		70.5	58,910	53	
25		64.2	42,640	50	
30		57.7	33,230	48	
35		50.6	27,040	44	
40		52.7	22,670	39	
45		33.5	19,460	33	
50		20.9	16,960	23	

It is evident that a construction engineer who wants to plan the lifting strategy for a project can use the data provided by the manufacturer for that specific model of crane. Currently, this type of planning is done either by hand or in some cases using specialized software provided by the crane manufacturer. If the construction engineer has access to a building information model of the structure, they could benefit from the three dimensional environment when planning a lift. Additionally, the yet to be constructed elements of the structure can be hidden in the BIM model to accurately portray the current status of the project. This can provide an actual representation of the latest progress of the construction phase. The generic hydraulic crawler crane models provided by REVIT[®] are not designed for such critical execution planning purposes. In order to make them beneficial, significant modifications would need to be made to the generic construction crane family each time it is utilized. This is most likely not worth the time and money spent on the process and may not produce desired accurate results for informed decision making. On the other hand, the power of a completely parametric model of a hydraulic crane can be harnessed by an experienced construction engineer to effectively plan the lift using the BIM model. In this case, the engineer would be able to place the crane at various locations on site and evaluate the boom length/angle required for each lift and plan the lift effectively. Not only this, the most effective locations for crane placement on site, over the life span of the project, can also be determined. This can result in the development of highly functionable site utilization plans that harness the power of BIM and takes the intricacies of the construction process into account.

Objects for Site Utilization Planning

Optimum site utilization plans minimize the labor involved with movement of materials so that workers can spend the majority of their time performing construction tasks. Jobsites that are clean and well-organized provide a working environment that has a positive impact on work moral and in turn result in high production during the work shift. According to Mincks and Johnston (2010), a site utilization plan should include:

1. Clearly designated areas on the jobsite for material delivery, material storage, temporary offices, and facilities.
2. Jobsite access to and from the jobsite and to work areas within the jobsite.
3. Movement of material on the jobsite, both horizontally and vertically.
4. Worker transportation –clearly laid out paths for personnel movement and access to the jobsite.
5. Temporary facilities – temporary offices, storage facilities, dry shacks, sanitary facilities, temporary water, power, and heat.

6. Jobsite security – temporary fencing, signage and barricades for the protection of the public from construction hazards on the jobsite.

In order to develop a site utilization plan using BIM with optimal effort, it is important to distinguish between objects that need to be defined to a significant level of detail and objects which can be defined generically with limited parametric control on their geometry and behavior.

Generic Objects Requiring Limited Parametric Definition and Control

The components that fall in this category include temporary facilities such as office trailers, waste bins, fences, etc. These objects do not have a significant impact on the construction execution process. A significant modeling effort does not need to be expended in modeling these objects. In order to model these low definition elements, one can use generic objects which have some graphical resemblance to the facility plan and the three dimensional geometric properties. Many useful ready-modeled construction site temporary facility families are available online through websites such as AutodeskSeek and RevitCity. By downloading families, a designer can compile an object library than can be reused on multiple projects. The benefit of using families is that the designer does not have to spend a substantial amount of time creating the objects needed to develop a site layout plan; however, if a unique object is needed for site layout planning the object can be created and saved within the object library. Most of the object families look realistic and can be easily comprehended, thus allowing for timely plan interpretation when actual objects need to be placed on the jobsite. Examples of free site layout planning objects available for download at websites such as www.revitcity.com, www.seek.autodesk.com, and www.bimstop.com are shown in Figure 4.

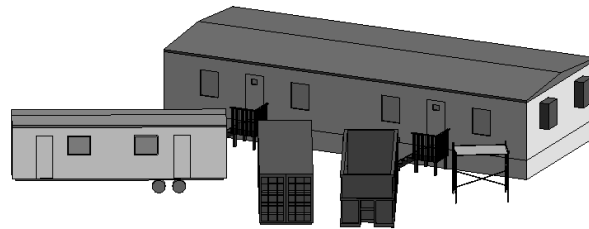

Figure 4: Site Services Facilities

Objects Requiring Significant Parametric Definition and Control Requirements

While the objects described in the section above do not require a significant level of definition, some objects are mission critical for the execution of the construction process. Lifting equipment, such as cranes described in the earlier section, fall in such category. Very well defined hydraulic crawler construction crane models can be utilized to determine their optimal positions at the site for various lifts; as well as, their lifting capacity at various boom lengths and angles. Parametric models of telescoping mobile cranes can be utilized to evaluate the viability of using the cranes at various stages of the project based on the access routes available for crane movement. Based on the best location of the crane, its ability to lift various objects can then be determined.

Tower cranes remain stationary through the construction project. A parametric three dimensional model of a tower crane could be utilized to determine the lifting capacity of the crane at various values of lifting radii; however, they can also offer additional benefits. For example, when planning the locations of the tower cranes used in the Audie L. Murphy Memorial Hospital Polytrauma Rehabilitation Center project in San Antonio, TX, Robins and Morton required safety approval from the Federal Aviation Administration to insure the locations of the tower cranes would not hinder the flight paths of helicopters carrying trauma patients to the top of the adjoining hospital. In this case, a three dimensional BIM model and a tower crane animation showing the maximum radius of the cranes and the flight path of the helicopters was used to expedite the approval of tower cranes placement on the project. Three dimensional BIM models are inherently easier to interpret, especially for non-technical users who may be part of the decision making process. Cranes are not the only category of construction equipment that could benefit from extensive parametric 3D modeling. Concrete pump trucks are utilized in many projects involving significant

reinforced concrete construction of substructure and superstructure elements of buildings. Parametric BIM models could be effectively used in such cases to plan concrete pours.

While, it is easy to recognize the benefits that can be obtained by creating well defined parameterized objects for site utilization planning, the effort and consequently the cost required for creating the object can be substantial. Software vendors such as AutoDesk cannot reasonably be expected to provide highly parameterized families for the wide variety of construction equipment produced by all manufacturers. In the case of various building design products, the equipment manufacturers will eventually have to provide these models to the users of their equipment. Some crane manufacturers have already started providing AutoCAD 3D models of their cranes to construction contractors who request them. In the near future, this trend is likely to continue on account of increased use of BIM in the construction industry as indicated on the SmartMarket Report. In order to promote standardization, it may also help to create specifications of the parameters that should be provided by equipment manufacturers in their BIM models. The list of parameters will most likely vary significantly across various categories of construction equipment. The advancement of parametric availabilities within model families will most certainly accelerate their adoption in the construction industry.

Four Dimensional Site Utilization Planning

The temporary facilities, construction equipment and processes over the life cycle of the construction project can vary significantly. While some facilities, such as site office trailers, are long term static facilities, many temporary facilities exist at the construction sites only for a short to medium duration. This inherently ever changing, dynamic nature of site layout is very difficult to visualize and capture using two dimensional paper based processes. Many tools such as Navisworks[®] can integrate the three dimensional objects in a building information model with the construction schedule to create 4D (temporal) simulations of the construction process. Traditionally, the 4D models are limited to the components of the building designed by various design professionals. With a little bit of creativity, a planner could add activities in a construction schedule which represent the mobilization and de-mobilization of various temporary facilities at the construction site. This schedule could then be integrated into the BIM model with the temporary facilities in it. This combination can be used to produce very powerful simulations of the creation and removal of various temporary facilities. This has the potential to improve the quality of the execution plan for a project.

Concluding Remarks and Areas of Future Research

Construction Site Utilization Planning has significant potential to improve the efficiency of construction operations, enhance schedule and cost performance of the project, and improve safety at the construction site. Use of Building Information Modeling can empower this process by leveraging the various models made available to the construction contractor by designers. BIM models are increasingly being used for constructability analysis, site utilization planning, and logistics by contractors. BIM models provide a very data rich, visual context for planning construction operations. For their use to become a standard operating practice, it is necessary that parametric objects be available to the construction contractors so that the cost associated with such planning becomes acceptable. This parametric three dimensional modeling environment can be utilized by the construction research community to integrate robust optimization algorithms into the planning process. In such a process, a part of the utilization planning will be done by the project manager based on their knowledge while the movement of manpower and materials can be optimized using the appropriate meta-heuristic algorithm.

References

Arikaran, P., Jayabalan, D. V., and Senthilkumar, R. (2010). "Analysis of Unequal Areas Facility Layout Problems." *International Journal of Engineering*, 4(1), 44-51.

AUTODESK[®] REVIT[®] (2014). "Creating Loadable Families." [WWW document] URL http://help.autodesk.com/view/RVT/2014/ENU/?contextId=REVIT_FAMILIES_GUIDE

Azhar, S. (2011). "Building Information Modeling (BIM): Trends, Benefits, Risks, and Challenges for the AEC Industry." *Leadership Manage. Eng.*, **11**(3), 241-252

Chau, K. W. and Anson, M. (2002). "A Knowledge-Based System for Construction Site Level Facilities Layout." *Lecture Notes in Artificial Intelligence*, 2358, 393-402.

Cheng, M. Y., and O'Connor, J. T. (1996). "ArcSite: Enhanced GIS for construction site layout." *J. Constr. Eng. Manage.*, **122**(4), 329-336

Dodds, Jason and Johnson, Scott (2012). "Mastering Autodesk Navisworks 2012." Wiley Publishing, Inc.

Elbeltagi, E. (2008). "Construction Site Layout Planning." *Lecture Notes*, Structural Eng. Dept., Mansoura University, Mansoura, Egypt.

Liggett, R. S. (2000). "Automated facilities layout: past, present and future." *Automation in construction*, 9(2), 197-215.

Mawdesley, M. J., Al-jibouri, S. H., and Yang, H. (2002). "Genetic algorithms for construction site layout in project planning." *J. Constr. Eng. Manage.*, **128**(5), 418-426.

McGraw-Hill Construction (2012). "The Business Value of BIM in North America: Multi-Year Trend Analysis and User Ratings (2007-2012). SmartMarket Report.

Mincks, W. R., and Johnston, H. (2010). *Construction Jobsite Management*, 3rd Edition, Delmar Cengage Learning.

Ning, X., Lam, K.-C., and Lam, M. C.-K. (2010). "A decision-making system for construction site layout planning." *Automation in Construction*, in press.

Osman, H. M., Geory, M. E., and Ibrahim, M. E. (2003). "A hybrid CAD-based construction site layout planning system using genetic algorithms." *Automation in Construction*, **12**(3), 749-764.

Retik, A., Shapira, A. (1999). "VR-based planning of construction site activities." *Auto. Constr.*, (8), 671-680.

Riley, D. R., and Sanvido, V. E. (1995). "Patterns of construction-space use in multistory buildings." *J. Constr. Eng. Manage.*, **121**(4), 464-473