

Motivation through Collaborative Virtual Reality Environments Earthwork Exercises

Lacey Duckworth, Dr. Tulio Sulbaran, Dr. Andrew Strelzoff

The University of Southern Mississippi
Hattiesburg, Mississippi

Dr. Randy Rapp

Purdue University
West Lafayette, IN

Finding means to motivate students to learn is rather difficult as each student has different needs when it comes to getting motivated. In most classroom settings, the only motivation for a student is the letter grade based on the performance of pen and paper pedagogy, which is given at the end of the school year. While this is enough motivation for some students, other students need more of a hands-on method for learning. Through the use of an emerging technology, Collaborative Virtual Reality Environments, students are provided with another method of motivation where they see immediate results of their actions and the pen and paper pedagogy can be reinforced. This paper discusses measuring the motivation of an excavation training simulator implemented for Purdue University.

Keywords: Collaborative Virtual Reality, Training Simulator, Earthwork Exercises, Occupational Safety and Health Administration

Introduction

The best method for enhancing students' thinking-skills is to get them motivated in the topic. Students who are highly motivated are more likely to absorb the material and have a better chance at successfully reiterating the material. On the other hand, students who are not highly motivated tend to not learn as well even when presented with enriched classroom exercises. Although students are motivated as a result of grade pressure, there has to be some other method of motivating the student to succeed in the exercise given. By using Collaborative Virtual Reality Environments, students, while taking the role of an avatar, could have hands on experience for learning as well as obtain immediate results from the instructor and other classmates which would provide several means for motivation levels. This paper discusses the results of an excavation training simulator test with Building Construction Management students at Purdue University in order to make the learning of the excavation process a more motivating exercise compared to the pen and paper pedagogy that currently exists. The students currently draw and submit a plan view of a building excavation selecting a slope on the basis of a soil description, by which they determine the Occupational Safety and Health Administration (OSHA) soil type. They typically get feedback about the slope determination a day or two after they do that homework however, faster feedback is preferred.

Background

The lack of motivation when educating students leads to both the unwillingness to succeed and the prevention of material comprehension. As stated by Constance Frith in "Motivation to Learn", the motivation to learn is personal and comes from within an individual but can be influenced by external factors. These external factors include: peaking ones curiosity in the subject matter, dividing the tasks into smaller segments with early success in order to develop confidence, measuring the students attitude toward learning is an intrinsic characteristic and not always demonstrated through behaviors, addressing the human needs according to Maslow's hierarchical needs, allowing students the ability to undertake challenging tasks on their own to prove to themselves that they can succeed, and addressing other external motivators such as making the material flexible in order to provide creativity, grades, as well as positive and negative reinforcement (Frith, 1997).

One method for addressing motivation in the classroom is by using one of the emerging technologies, Simulations within Collaborative Virtual Reality Environments (CVRE). A CVRE not only allows students to interact with a

computer-simulated environment and obtain real time results based on their interaction but also allows students to interact with others while in the environment either to assist in a task or to communicate with on the particular subject matter. According to Gloria Antifaiff, "the integration of technology should serve to guide, expand and enhance learning objectives". This paper presents the results of assessing the motivation for learning with the excavation training simulator built for Purdue University.

Learning Objectives

Excavation is a very dangerous task in the construction field. OSHA cites open trench work as the fourth deadliest job in United States (OSHA Compliance Safety Training, 2009). Wider excavations may seem less restricted in movement and thus less dangerous in the event of slope failure. However, during construction operations the gap between a slope toe and an immovable object on the floor of the cut may be reduced to mere trench widths (15-feet or less) and jeopardize workers as much as do narrow trenches. All excavated slopes rightfully comply with OSHA standards. Therefore, it is critical to ensure students understand the appropriate process and standards before entering the workforce. To determine if simulating the exercise process in a CVRE would help motivate students to better perform this task required simulating the excavation process in a CVRE and then measuring the students motivation by using a motivational survey.

The architecture for implementing this simulation is unlike other simulations for CVREs. Existing methods for implementing a simulations within CVREs requires embedding the actual simulation within the CVRE, which can cause performance and scalability issues as well as limit the pieces of simulation to be implemented due to script size limits. Performance issues occur because the server remains busy at all times updating the environments appearance and maintaining user information. Scalability issues arise because there is no other method for quickly adding methods to the simulation which requires a complete rewrite of the script. The solution for this is to move the simulation external to the CVRE which entails the network architecture as seen in figure 1 below. Utilizing this type of architecture for implementing the desired simulation in a CVRE is unlike any other as the simulation can be quickly modified to enable the addition of any component.

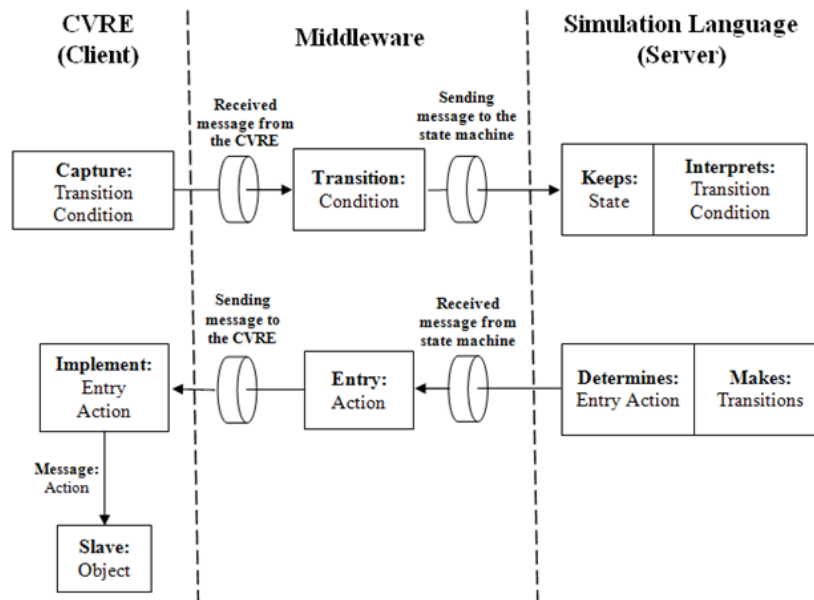

Figure 1 – network architecture for moving the simulation external to the CVRE.

Using this architecture, the excavation training simulator was implemented so that students could answer the following questions

1. What soil type does the exercise best describe?
2. What is the appropriate slope method for the soil type provided?
3. What is the appropriate height/depth ratio for the soil type and slope method selected?

4. What is the correct bank measure volume of the excavation?

Based on their selections, the program provided prompt feedback, which could be either a successful or failed excavation. A successful excavation shows the project site being excavated whereas a failed excavation which occurs when the user selects a slope that is too steep for the soil type, results in a small landslide occurring partially burying the excavator. Figure 2 below shows the interaction board that contained the questions with buttons for interacting with the board.

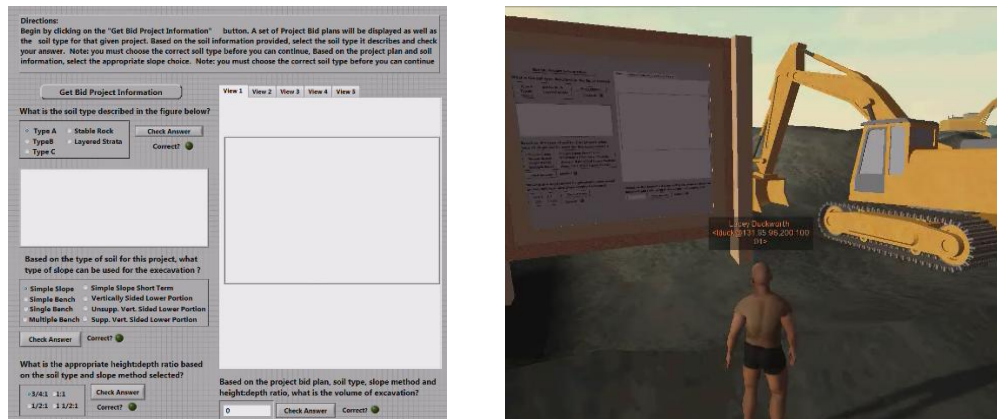

Figure 2 – interactive board in the CVRE.

To answer the questions during the simulation, students are presented with one of four projects (house, apartment, hospital, or industrial) and one of five OSHA soil types (Stable Rock, Type A, Type B, Type C, Layered Geological Strata) to use for answering a specific question. From the different combinations of projects, soil types, and the selections of the students the visual made in the CVRE can take on various forms. When walking through the exercise, if a student is unsure of his/her answer they have the ability to interact with other students in order to ask for assistance or watch how they answer questions which brings the collaborative aspect into this simulation. While other simulation have this capability, a feature that some may not include the ability for a simulation to be added on top of the existing which the architecture this simulation was built provides the means to handle additions. For example, this simulation only deals with earthworks which was suitable for the project at hand. However, if an extension to this simulation was desired so that students could also answer questions about the foundation and foundation work would appear implementing this would require a rework of the simulation. A rework is required because most simulations do not use a network architecture which prevents additions from being added easily.

Experiment

The experiment consisted of 26 Purdue University students of the Construction Site Planning course who volunteered to log into the CVRE and complete the excavation training simulator exercise with the aid of a written tutorial. Once completing the training simulator in the CVRE, students were asked to complete an online survey in order to determine their degree of motivation. The motivational survey was designed based on the Intrinsic Motivation Inventory (IMI) which was developed by Deci and Ryan. This document is a measuring device to help determine the participant's subjective experience related to a specific section in laboratory experiments. In the IMI, there are several categories that relate to one's degree of motivation. These categories include:

- Interest/enjoyment
- Perceived competence
- Effort/importance
- Pressure/tension
- Perceived choice
- Value/usefulness

Using these categories, a 36 questions, as seen in the appendix, was developed in statement form where the student could choose strongly agree, agree, undecided, disagree, or strongly disagree. Examples of questions on this survey from each of these categories include:

- This activity did not hold my attention at all.
- I couldn't do this activity very well.
- I didn't try very hard to do this activity.
- I did not feel nervous at all while doing this activity.
- I didn't really have a choice about doing this task.
- I believe doing this activity was beneficial to me.

In additions to the statement questions, students were also given two questions:

- Did they think this activity should be available to upcoming students?
- Should this activity be modified for the upcoming students? If so, what modifications?

Lastly, students were given the ability to leave additional comments. Once the data was collected from these surveys, the questions were grouped by the categories and statistical methods were use to determine the degree motivation for each section.

Results

The figures below display the results of the motivational survey based on the categories: interest/enjoyment, perceived competence, effort/importance, pressure/tension, perceived choice, and value/usefulness.

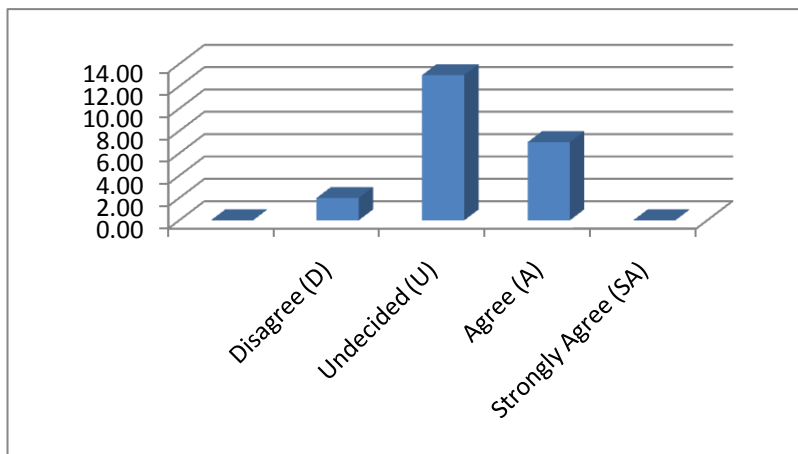

Figure 3. Chart displaying the interest and enjoyment of this activity

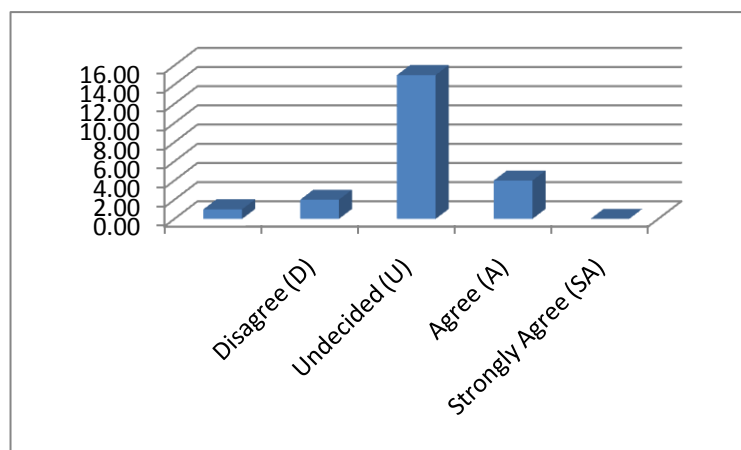

Figure 4. Chart displaying the perceived competence of this activity

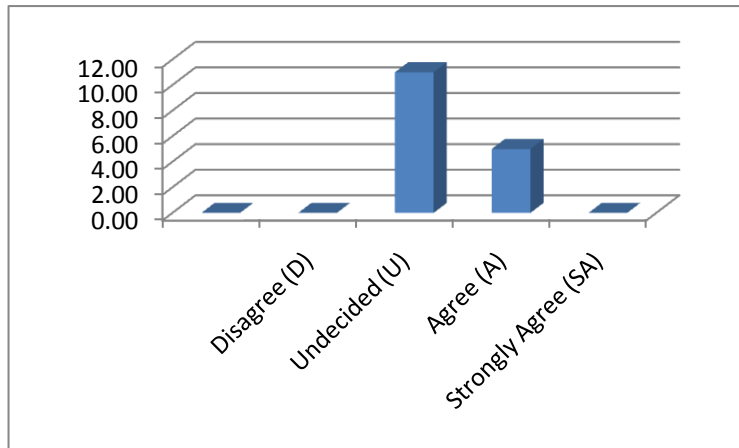

Figure 5. Chart displaying the effort/importance of this activity

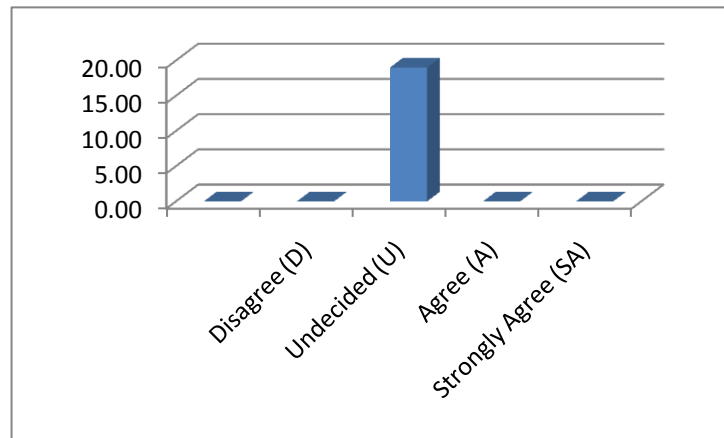

Figure 6. Chart displaying the pressure/tension of this activity

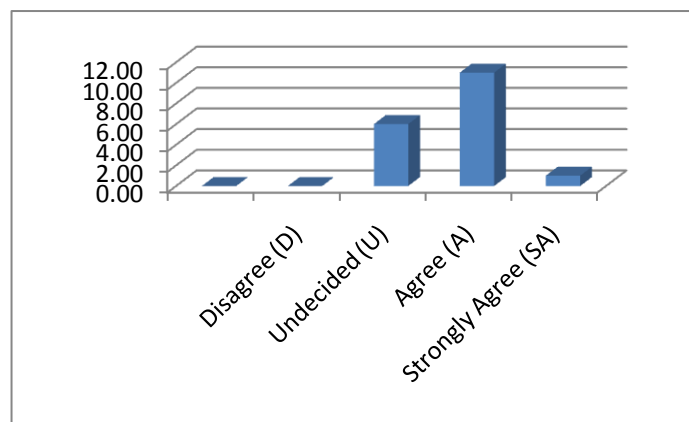

Figure 7. Chart displaying the perceived choice of this activity

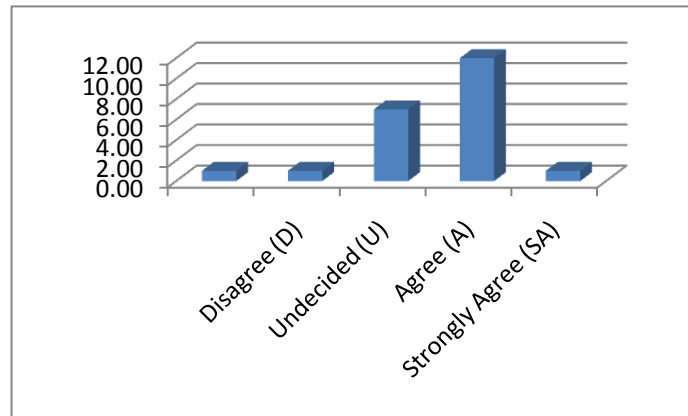

Figure 8. Chart displaying the usefulness of this activity

While most students agreed that this activity should be available to upcoming students, all who were in agreement commented that the training simulator needed to be enhanced before it was made available to future students. The responses to the motivational survey ranged mostly from undecided to the strongly agree because the exercise did not perform as expected. Issues that lead to poor performance of the exercise included:

- The exercise did not consider students clicking on the same button more than twice therefore tripping the simulator.
- Some students were not able to download the Collaborative Virtual Reality Viewing software.
- Some students could not log into the server on their end due to low internet connection.
- The servers crashed during the experiment requiring the simulation to be restarted.
- Intermediate responses were not available to ensure students their answer to each question was submitted.

Although this test case was performed on a small number of students, the data gathered provided enough information to determine if the proposed network architecture was suitable for using to implement other simulation in CVRE. By using the information gathered from this test case, if changes were made to improve the training simulator, there is a strong chance that students who were undecided might change their answer to the survey questions to indicate they agree or strongly agree with the statement about the training simulator. If this test were to be conducted again, the network architecture would need to be re-worked to prevent errors in the simulation.

Future Works

Based on the feedback from the test case, enhancements need to be made to the training simulator so that students feel motivated to complete the exercise. Enhancements to the training simulator require adding code to prevent students from skipping ahead or going back to other questions, providing indicators for answers submitted, and developing the code on a more stable server. After implementing these enhancements, another test case would be performed in the same manor of the first test case resulting in a motivational survey after the experiment.

Appendix

For the first set of questions students could answer Strongly Agree, Agree, Undecided, Disagree, or Strongly Disagree.

1. I had fun doing this activity.
2. I was pretty skilled at this activity.
3. I didn't put too much energy into this activity.
4. I felt pressured while doing this activity.
5. I did this activity because I had no choice.
6. I believe this activity was of some value to me.
7. I put a lot of effort into this activity.
8. I thought this activity was quite enjoyable.

9. I am satisfied with my performance at this task.
10. I think doing this activity will help me better learn the importance and benefits of correct construction excavation.
11. I did the activity because I wanted to.
12. I felt very tense while doing this activity.
13. I tried very hard on this activity.
14. This activity did not hold my attention at all.
15. I was very relaxed in doing this activity.
16. I believe I had some choice about doing this activity.
17. I think this is an important activity.
18. I think that I was pretty good at this activity.
19. While I was doing this activity, I was thinking about how much I enjoyed it.
20. I think this is important to do because it can help me understand the consequences of poor excavation.
21. I thought this was a boring activity
22. I did not feel nervous at all while doing this activity.
23. I felt like I had to do this.
24. I believe doing this activity was beneficial to me.
25. I think I did pretty well at this activity, compared to other students.
26. I was anxious while working on this task
27. I enjoyed doing this activity very much.
28. I didn't really have a choice about doing this task.
29. I would be willing to do this again because it has some value to me.
30. I couldn't do this activity very well.
31. I didn't try very hard to do well at this activity.
32. I think that this activity was useful for learning how to correctly excavate a construction site.
33. I felt pretty competent after working at this activity for a while.
34. I think this activity is very interesting.
35. I felt like it was not my own choice to do this task.
36. It was important to me to do well on this task.

For the next set of questions students could answer yes or no.

1. Should this activity be given to the upcoming students?
2. Should this activity be modified for the upcoming students?

The next questions allowed students to key in their own personal answer.

1. If you answered yes to the previous question, what modifications would you suggest to make to the activity to make it a better educational experience?
2. Comments

References

- Antifaiff, Gloria. (2000, April). Integrating Technology into the Curriculum. [WWW document]. URL <http://www.usask.ca/education/coursework/802papers/antifaiff/antifaiff.pdf>
- Deci, Edward and Ryan, Richard. (2009). Intrinsic Motivation Inventory (IMI). [WWW document]. URL http://www.psych.rochester.edu/SDT/measures/IMI_description.php
- Frith, Constance. (1997). Motivation to Learn. [WWW document]. URL http://general.utpb.edu/FAC/keast_d/Tunebooks/pdf/Motivation.pdf
- OSHA Safety Training. (2009, October 22). OSHA on Safety for Trenching and Excavation Workers. [WWW document]. URL <http://osha-safetytraining.blogspot.com/2009/10/osha-on-safety-for-trenching-and.html>. <http://osha-safetytraining.blogspot.com/2009/10/osha-on-safety-for-trenching-and.html> (Accessed 24Aug10.)